

Gas cooler RKVD

Series RKVD is consisting of gas coolers with double row of axial fans, suitable to be used in refrigeration and air conditioning, when installation is about plant with transcritical CO₂.

Thanks V shape configuration, these gas coolers can reach high capacity with limited dimensions.

Capacity range from 250 to 1760 kW.



Casing

The frame design provides high rigidity.

Casing manufactured from galvanized steel powder painted colour RAL 9002, corrosion resistant.

All rivets and bolts are in stainless steel AISI 304

Heat exchanger

Heat exchanger is equipped with suspending tubes system that avoid the contact between tubes and frame and it provides full protection of the heat exchanger against vibrations and thermal expansions.

The coil is realized with rippled alloy copper pipes K65 and aluminium fins.

PS 120 bar and TS -40 / +140 °C, according to standard PED 2014/68/EU.

Fans

High efficiency fans provide high performances with limited power consumption. They are complete of thermal protection, protection grid according to EN ISO 13857, dynamically and statically balanced and according to ErP directive.

AC and EC fans are available with diameter 910 mm with motors with external rotor, insulation class F, standard protection degree IP 54 (EN 60529).

Noise level from 35 dB(A) at 10 m (EN 13487).

Standards

The products are designed and manufactured according to following EU Directive:

- PED 2014/68/UE
- 2006/42/CE (Machinery Directive)
- 2014/35/UE (LVD Directive)
- 2014/30/UE (EMC Directive)

Options

- Fins spacing 2,1 – 2,3 – 2,5 – 3,0 – 4,0 mm
- Special fans for application with high static residual pressure
- ATEX fan
- Stainless steel pipes AISI 304 or AISI 316L
- Plane aluminium fins for easier cleaning
- Copper fins
- Stainless steel fins AISI 304 o AISI 316L
- Epoxy coated Aluminium fins
- Protective coating on coil
- Vertical air flow installation kit
- Vibration dampers
- Switch off for fans
- AC and EC fans wiring
- Casing with special painting
- Stainless steel casing AISI 304 or AISI 316L
- Adiabatic system "Spray System"
- Adiabatic system "PAD" (supplied separately)

Code key

R	K	V	D	090	6	C	6	D
1	2	3	4	5	6	7	8	9

1. Refteco
2. Gas cooler
3. V Shape
4. Double row of fans
5. Fan diameter (mm)
6. Number of fans
7. Size of coil (number of rows)
8. Poles number of fans
9. Fans connection (D = triangle, Y = star, S = single phase)

Dimensions

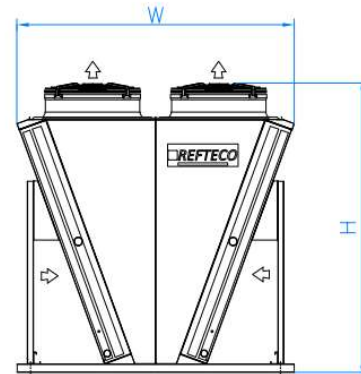
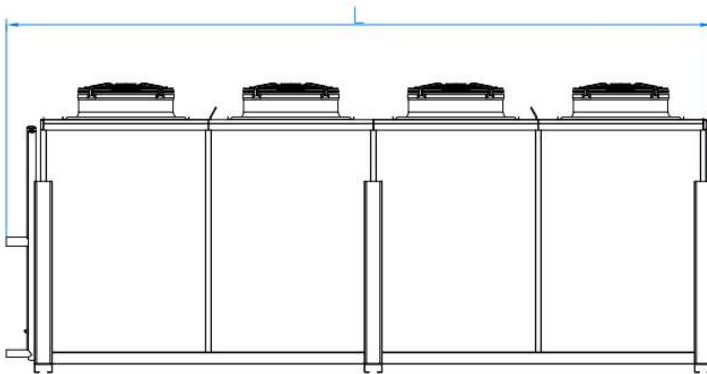

Number of fans	Dimensions (mm)		
	L	W	H
4	3190	2203	2451
6	4590	2203	2451
8	5990	2203	2451
10	7390	2203	2451

Warranty

Products are granted, against any construction defect, for 24 months from shipping date. Damages caused by normal wear, corrosion, faulty assembly or maintenance are excluded.